



Corri Color Applications

Roof and wall applications where the environmental conditions do not pose a significant corrosion risk to metal sheeting.



Colours and Thicknesses

	Thickness (mm)	0.5	0.6
Colour		Slate Grey Juniper Green Turf Brown Black	Slate Grey Juniper Green Black

Material

Substrate: S220GD+Z225 to EN 10346:2009

Coating: Underside: 10um Primer/Polyester
Weather side: 25um Primer/Polyester

Available Lengths

Made to order in lengths of .1 – 12 m.

Corricolor is also available ex stock as listed below:

	Thickness (mm)	0.5
Colours		Slate Grey, Juniper Green
Stock lengths		3 m (10') 3.7 m (12') 4.3 m (14') 4.9 m (16')

DPC Barrier

To prevent corrosion caused by contact with wet, green or treated timber a DPC barrier must be used when Corricolor is fixed to timber purlins.

Packing and delivery

All deliveries, unless indicated otherwise, are by road transport with packaging to suit land delivery. As a general guide pack sizes are limited to two tonnes and the entire pack is wrapped in polythene. Offloading is the responsibility of the client.

Storage & Handling

Water ingress between sheets will have a negative effect on the performance of the sheet. Wrapping is only a temporary protection for transport purposes and is not suitable for outdoor storage.



Quality



Curving Information

Overview

The complete range of Duggan Profiles sinusoidal sheeting can be curved or cocktailed subject to the manufacturing limitations that are described below. 0.7 mm material is recommended as it more easily retains the curved profile.

Available Lengths

The total length of curved or cocktailed sheets should be limited to 4.876 m (16').

Requirements for manufacture of Curved Sheets

In order to curve sheeting the curved length and rise at mid span is required as indicated in the diagram below.

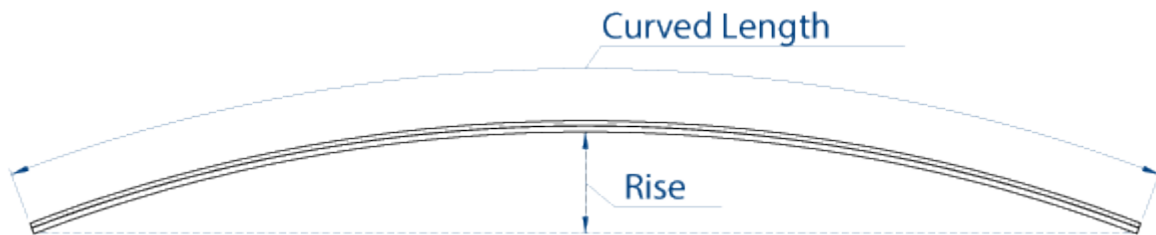

Stock

Curved ridges are available ex stock in 0.55 mm Corrifarm 14/3 & 10/3 Slate Grey & Juniper Green.

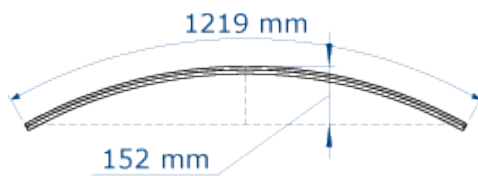



Application Of Non Drip Condensation Controls on CorriColor



Overview

NonDrip condensation control membrane is specially designed to help control condensation and prevent dripping in non-insulated metal buildings. It can be applied on our range of 14/3 corrugated or 1000/32 box profile sheeting.

Application

NonDrip membrane can help control condensation in an environment where the condensation appears cyclically. In order to work it needs to get dry in between cycles so it should not be used in buildings where relative humidity approaches saturation for extended periods. To facilitate drying adequate ventilation is necessary. Without proper ventilation the risk occurs of the build-up of moisture and droplet formation.

Installation

Care must be taken to avoid penetration of rainwater due to capillarity through the side or end laps. The following should be observed during installation:

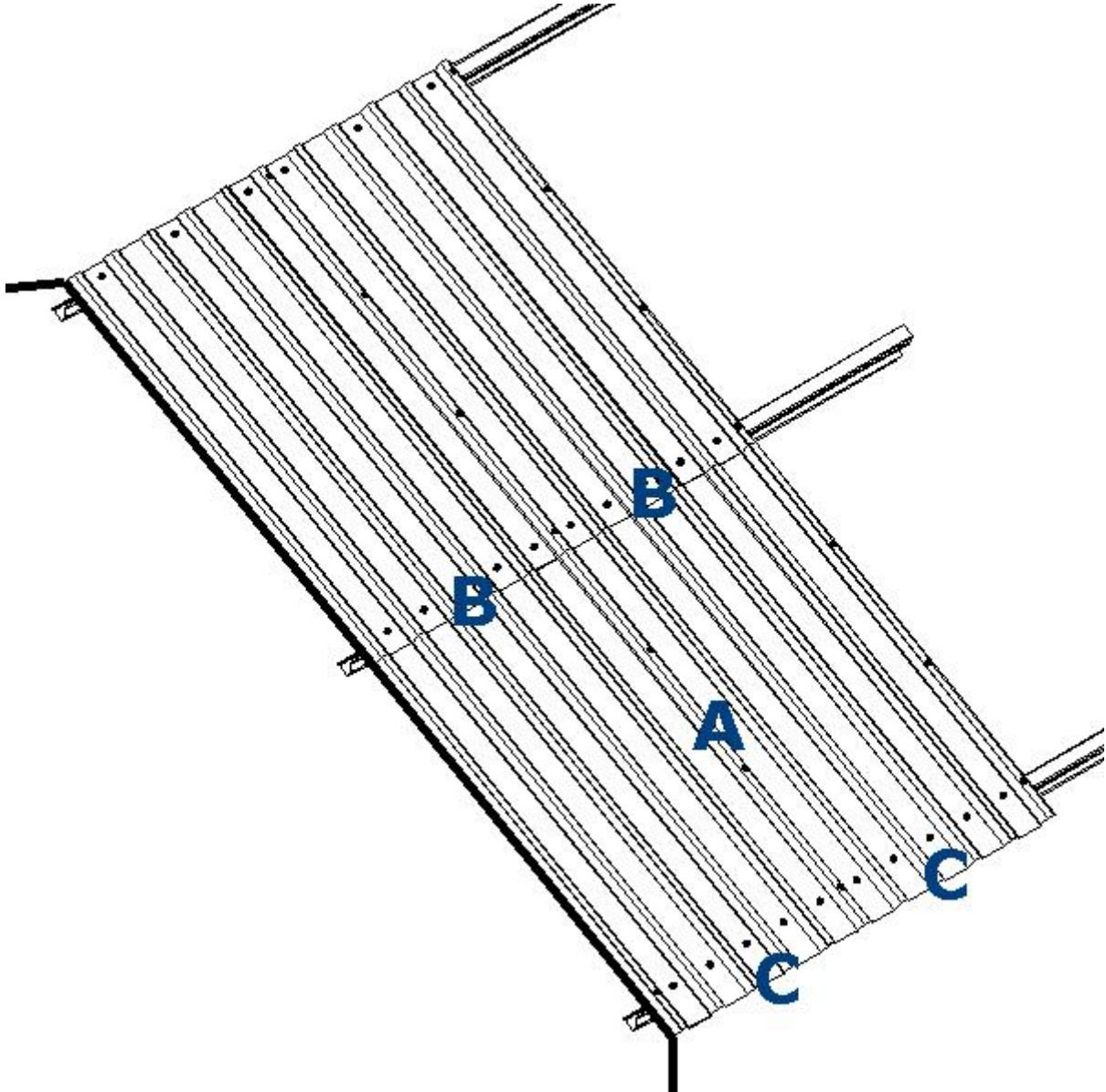

Vertical overlaps (A)

All profiled sheeting with NonDrip is supplied with the vertical side lap left uncovered. The capillary effects in the lateral direction (A) can be prevented by installing sheeting so the interior side is completely covered with NonDrip membrane (no bare metal visible).

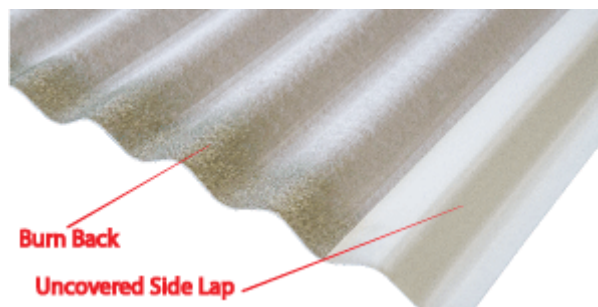

End laps at (B) and (C)

Sheeting is supplied with the NonDrip membrane flame sealed (burn back) at one end. To



avoid penetration of rainwater due to capillarity through horizontal overlaps B and C the following should be observed:

- The burn back should be at the downslope end of the sheet.
- The overhang of the eave above the gutter should be at least 15 cm to avoid rain water penetrating into the building. This part of the roof is permanently ventilated in the outside air.

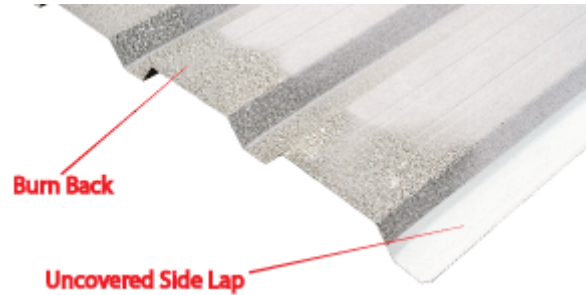

Ventilation

Key to the working of NonDrip™ is sufficient ventilation within the building envelope, to allow it to dry. The air flow movement and temperature within the building structure, will determine how quickly the NonDrip™ membrane will return to its original dry state. The build up of condensation can be reduced in the first place by the use of natural ventilation provided by eave, ridge and wall openings.

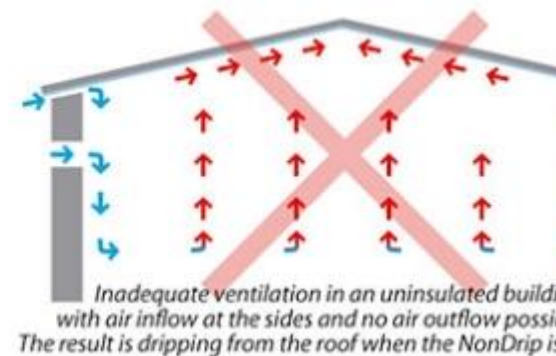
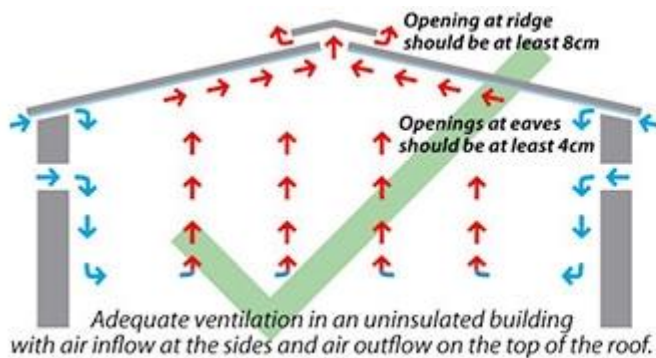

Absorption capacity

The water absorbency rates listed below were found from laboratory testing. As the roof pitch increases the absorption decreases under the influence of gravity.

Absorption & Drying Properties

Absorption at roof pitch	Unit	Value	Conditions
Absorption at 0 degree*	g/m ²	1037	100%RH, ΔT:17°C
Absorption at 10 degree/m ²	g/m ²	716	100%RH, ΔT:17°C
Absorption at 30 degree	g/m ²	538	100%RH, ΔT:17°C
Absorption at 45 degree**	g/m ²	394	100%RH, ΔT:17°C
Drying speed***	g/m ² /h	80	50%RH, 23°C



*With the sheet laid flat, and the relative humidity within the building at 100%, and the temperature on the inside of the building 17°C higher than the outside temperature, 1037 g/m² water was absorbed by NonDrip before it started to drip.

**This is an average time to drip for a roof pitch of 20 degrees given the relative humidity within the building at 100%, internal temperature of 40 degrees and the temperature on the inside of the building 17°C higher than the outside temperature. If the roof pitch is increased the time to drip will be somewhat shorter while lower angles will exceed 6 hours.

***With the relative humidity within the building at 50%, and the temperature on the inside of the building at 23°C, the drying speed was 80 g/m²/h.

Clearlights

Due to the risk of droplet formation on the underside of the light, clearlights are not recommended on a roof with NonDrip.



Purlins

All prepainted metal sheets, including those with NonDrip, should be separated from wet, green or treated timber purlins by a DPC strip.

Corrosion resistance

NonDrip™ does not negatively impact the corrosion resistance of the sheeting to which it is applied. The value of any guarantee supplied with sheeting will not be affected when NonDrip is used.

Chemical resistance

NonDrip should not be exposed to any solvents. Special care should be taken when using disinfectants. The disinfectant to be used should be tested on a small area to verify its effect. High pressures or hard brushes should not be used on the NonDrip membrane.

Installation precautions

To prevent damage to the NonDrip™ membrane, avoid rubbing the sheets together or against the roof structure.